

Trochoid Pump Lunary Pump Instruction Manual

Important

Read this manual thoroughly and carefully before installing or selecting a pump.

Follow all instructions carefully to ensure the correct and efficient pump installation and operation.

This manual contains suggestions and instructions on pump selection, installation, operation, and troubleshooting.

Failure to observe this manual prior to operation may result in personal injury and/or equipment damage.

Store this manual in a safe and readily accessible location for future references



Nippon Oil Pump Co., Ltd.

Trochoid Pump and Lunary Pump(GPL) Instruction Manual

For Safe Pump Operation

Safety

- Safety Equipment 2
- Safety Measures 2

Pump Installation

- Installation 3
- Installation Positions for the Trochoid Pump, Trochoid Pump with Motor, Trochoid Pump with Motor and Base Coupling, Lunary Pump with Motor and Base Coupling 3
- Installation Site 3

Pipe Arrangement

- Pipe Connections 4
- Types of Pipes and Couplings 4
- Discharge Pipework 6
- Filters 6

Preparations

- Before Operation 7
- Test Run 7
- Regular Inspections 8

Maintenance

Warranty

Pump Selection

- Necessary Flow Rate 9
- Necessary Pressure. 9
- Relief Valve Set Pressure..... 9
- Applicable Liquids..... 10
- Ambient Temperature..... 10
- Oil Temperature Range. 11
- Applicable Viscosity Ranges..... 11
- Rotation Direction. 12

Motor Selection

- Required Power For the Pump 12
- Applicable Voltage and Frequency. 13
- Surroundings of the installation site..... 13

Pump Drive Method



- Attachment Method..... 13

Suction Capacities

Troubleshooting Chart

For Safe Pump Operation

Be sure to obtain a thorough understanding of all safety measures. Always conduct the indicated precautionary steps and safety measures. When you see the following symbols and titles in this manual, be alert to the potential for personal injury or equipment damage.

-  **Danger:** Failure to follow the instructions will result in death or serious personal injury.
-  **Warning:** Failure to follow the instructions can result in death or personal injury.
-  **Caution:** Failure to follow the instructions can result in death or personal injury.

Safety

•Safety Equipment

- Be sure to equip motor with an “Earth-Leakage Circuit Breaker (ELCB)” or overload protection equipment. Use this equipment only after confirming that the ratings are within the prescribe ratings stated on the motor’s name plate.
- Be sure to comply with local electrical codes and regulations.

 **Caution:** Failure to use “Earth-Leakage Circuit Breakers(ELCB)” and overload protection equipment could result in damage to the equipment or motor burnout.

- To avoid damage to pump outlet, install a galvanometer, pressure sensor, or such other devices in the pump’s outlet line to detect dry running.
- The oil seals and packings cannot be used indefinitely.
- Install the pump in a safe location, or provide an protective cover or device to prevent personal injury or equipment damage caused by an accidental oil leaks.

•Safety Measures

- Keep children or other people incapable of judging risks away from the pumps.
- Protective equipment should be installed to prevent fingers, hands or other objects from getting caught in the rotating or moving parts.

 **Warning:** Getting your fingers, hands or articles caught in the rotating or moving parts may cause unexpected injury.

- Do not touch a pump or motor during or immediately after the operations.

 **Warning:** Touching the pump or motor during the operation may result in burns.

- There may be sparks from the centrifugal force switch section when starting up certain single-phase motors (IME200S, 2ME200S, 2ME400S, 2MY750S).

 **Danger:** Do not place any flammable liquids or materials in the area surrounding the motor. Such items could catch fire.

Pump Installation

●Installation

- The pump should be installed at a position that is within 1m above or below the oil surface level.
- It is advisable to mount the pump at a position where the suction port is above the height of the oil surface level.
- Please consult us if the pump should be used outside the specification range as stated above.



Caution:

Installing the pump at a height of more than 1m above the oil surface could result in poor suction, depending on the operating conditions.

●Installation Positions for the Trochoid Pump, Trochoid Pump with Motor, Trochoid Pump with Motor and Base Coupling, and Lunary Pump with Motor and Base Coupling

- There are no particular restrictions on the mounting directions when installing only the pump itself.
- When installing a Trochoid pump with a motor, the pump cannot be installed in a position higher than the motor (as seen from the horizontal position).
- When installing a Trochoid pump with a motor and a base coupling, the foundation where the base plate will be attached must be level.
- Align the attachment anchor so that it can be smoothly fitted to the base plate and the motor attachment holes.



Caution:

The motor may get damaged if the motor and Trochoid pump are installed incorrectly.



Caution:

If the installation site is not level, or if there is forcible installation in which the installation holes are not in exact alignment, the angle plate or base may get damaged or the axis may be deviated, which result in pump galling and ruining the pump.

Installation Site

The equipment should not be installed in locations with lots of dust, high or low temperatures (refer to P.10 "Ambient Temperature"). Please consult us on what measures can be taken when the equipment must be used in special environments (e.g. a place in which the pump will be exposed to water, place with high vibration or high humidity) other than the typical indoor installation sites.

Pipe Arrangement

- The maximum torque allowances when tightening the screws for the Trochoid pump's pipe connections are as shown in the table below.

Diameter Rc	1/8	1/4	3/8	1/2	3/4	1	1-1/4	1-1/2
Torque N•m	10	20	20	25	30	70	80	90

⚠ Caution: The pump bore may get damaged if these values are exceeded.

⚠ Caution: The use of seal tape or liquid sealants may result in reduced frictional resistance and over tightening, which in turn could damage the pump bore.

•Pipe Connections

- Make sure that the pipe connections are securely tightened and completely sealed to prevent leaks or intake of air.
- Always be sure to use pipe supports so that the pipes are self-supported and will not place any weight on the pump.
- Make sure that the pipe lengths and angles are correct when connected so that no unnecessary strain is placed on the pump.
- A pressure gauge should be installed so that pump conditions can be easily monitored.
- Stop valves, union jacks and some other couplings should be used to make pump maintenance easier.
- When handling oils with high viscosities, select pipes with diameters bigger than the pump to minimize pressure loss.
- Some of the high-pressure hoses and other parts have narrow internal diameters. Therefore, be sure to check not only the inner diameter of screw-in sections, but the whole area of the pipe as well before use.
- It is recommended that an air vent valve in discharge line and additional priming hole in suction line be provided to prevent possible startup troubles.

•Types of Pipes and Couplings

- All pipes must be cleaned thoroughly before connected to the pump. Some pipes may have dust from storage or threading debris remaining inside. Be sure to flush out all pipes to ensure that they are thoroughly clean before use.

⚠ Caution: The pump and connected equipment may become damaged if the pipes are not adequately clean.

⚠ Caution: Do not attempt to flush the pipes after attaching to the pump.

⚠ Caution: Test the pipes for air tightness before installing the pump.

● **Pipe Arrangement for Suction Side**

- For the suction side, select pipes with diameter that will keep the fluid velocity in the pipe at 1.5m/s or less and suction resistance at -0.03MPa or less.
- Make sure that the total pressure resistance of devices installed on the suction side of pipes, filter and valves in the pump suction line is smaller than 0.03MPa.

〈Calculation〉

$$\text{Fluid Velocity (m/s)} = \frac{\text{Pump Flow Rate (m}^3\text{/s)}}{\text{Pipe Cross-section Area (m}^2\text{)}}$$

⚠ Caution: Trapped air or foam inside the pipes may result in pump noise, vibrations and heating, which in turn could ruin the pump.

- Calculate the suction head based on the minimum oil level.

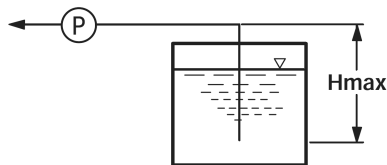

- Keep the suction-side piping as far away as possible from the return port of the relief valve or actuator so that there will be no negative influence from the returned oil.

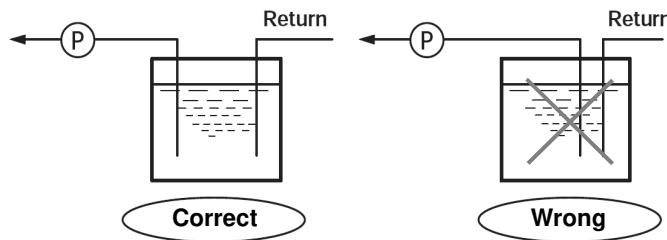

- Piping in the suction line should be as short as possible and with minimum number of bends.
- Inspect all of the valves thoroughly, cocks and couplings before assembling the pipes. Do not use any items with cavities or narrow ports.
- When bending or soldering the pipes, make sure that those pipe bores do not become smaller.
- Make sure that pipe inside diameter doesn't change throughout the pipe.
- Make sure that the opening section of the packing is cut away in accurate diameter and without any burrs.
- Make sure that air doesn't enter the pipes.
- It is recommended that suction pipes with bore diameter of one or two size larger be selected to reduce suction resistance if pumping oil with viscosity of ISO VG68 or higher in viscosity.

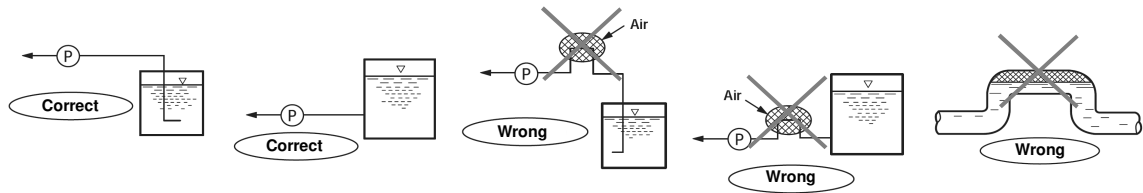

- Use gate-type valves when installing valves.
- If the pressure still remains inside the pipes in discharge line after the operation is stopped, a non-return valve should not be installed in suction line but in discharge line.

⚠ Caution: Make sure that the pressure in suction line won't exceed 0.03MPa. Excess pressure in suction line may cause oil seal damage, oil leakage. Special attention will be required particularly if you use forward and reverse type Trochoid pump.

● **Discharge Pipework**

- Select pipes which is wide enough to allow the fluids flowing through the discharge line at a speed of 3m/s or less.

● **Filters**

- It is recommended to Install suction filter of 150-mesh with as large capacity as possible if operated in a normal condition.
- Select filters with a passage resistance of 0.01MPa or less after confirming the manufacturer's specifications.
- The purpose of installing suction filter is to remove large objects that could hamper normal pump operations. Even very tiny object passing through the filter could significantly shorten the pump service life. Therefore, the oil used with the pump will need to be replaced on a regular basis, or cleaned regularly with a filter which is smaller than 11-micron openings.

⚠ Caution: Foreign objects mixed in the oil may significantly shorten the pump service life or damage the pump. Very fine objects which can pass through the suction filter also can cause performance drop, shortened service life, oil leaks depending on the use environment. Therefore, the filters need to be cleaned on a regular basis. Continuous use of clogged filters may result in an abnormal noise, vibrations and poor discharge.

Preparations

●Before Operation

- Check the direction of the pump rotation, suction port and discharge port.
- The rotation direction for our NOP motors (which is specially customized to work with NOP pump), is indicated on the wiring plates on the motor frame or terminal box section. Make the necessary connections after first checking these directions. If using our NOP motor confirm the direction of motor rotation before wiring, which is indicated on the wiring plate attached to the motor frame or terminal box.

- 1) Our NOP motor (3-phase power source) is designed to rotate in the standard rotation directions when wired in accordance with the wiring diagram as shown below.



- 2) Some types of general-purpose motor (3-phase) equipped with a base coupling may need to be wired differently from the diagram above, if that will be the case, wire the connections in accordance with wiring plates on the pump.

**Caution:**

Mistakes in the rotation direction and positioning of the suction and discharge ports could result in oil leaks or damage to the pump.

- Confirm whether the tank on the suction side is filled with clean oil.
- Confirm that there are no loose sections in the piping.
- Confirm that the entire pipe circuit is fully opened.
- Confirm that the valves around the pump are all fully opened.
- On the initial startup, turn the pump on and off quickly for a few times to confirm that the motor is running in the right direction.
- There is no ON / OFF switch on our pumps. It will start just after the wire is connected to the power supply. So, make sure that the power is completely disconnected before performing the wiring.

●Test Run

1) Dry Run

- Do not run the pump dry for more than 10 seconds. Stop the operation if the pump cannot prime oil.
- When it takes long time until the pump starts to draw oil, pour oil into suction pipe beforehand.

●Daily Start-up Inspection

- Be sure to make the necessary inspections every time before start-up. In particular, for oil leaks from the pump or pipes, abnormal noise and heating.



Caution:

If any abnormalities are discovered, immediately stop the pump and check for the problem area.

●Regular Inspections

- If the pump is used as an important safety parts, regular inspections should be performed at least once a year to ensure that they are operating correctly.
- These inspections should be carried out in our plant or facilities approved by us.

Maintenance

- Seal kits and spare parts should be kept on hand to deal with sudden faults or poor operation due to aging deterioration.
- The most common reason for poor performance is the use of fluids that have become dirty or degraded. Therefore, the oil replacement and other maintenance work should be performed on a regular basis.
- Be sure to cease all operations and perform necessary inspections and maintenance if there are any abnormal sounds, heating or other abnormalities when using a motor that had been kept in storage for an extended period of time.
- The coupling and oil seals used for the Trochoid pump and motor are consumable parts and so will need to be replaced on a regular basis (1 year or 8,000 hours of use).
- The pump service life will become shorter than 1 year or 8,000 hours of use if it is operated in an environment other than as stated above
- There are certain types of seal-kit that we cannot supply, such as ones for fuel oil, cutting-oil or heat-resistant types.

Warranty

- Faults caused by conditions outside the stated specifications or attributed to foreign matter or other external causes are not covered by the warranty.
- The terms of warranty is for 1 year after the delivery or 8,000 hours of use, whichever occurs first. The warranty applies only when operated within the product specifications and in accordance with the “Instruction Manual for Trochoid and Lunary Pumps” stated in this Trochoid Pump Catalog.
- The warranty doesn’t cover any faults caused by any modifications or disassembling of the pump made by customer.

Pump Selection

●Necessary Flow Rate.

- Refer to the Trochoid Pump Catalog or the drawings. (Catalog values are just for reference only and not for guaranteeing the performance.)
- The discharge flow rate will vary depending on the type of oil you use, temperature and pressure. (Flow rate varies depending on the pump use conditions and environment.)
- Pumps that provide plenty of leeway should be selected.

●Necessary Pressure.

- Refer to the Trochoid Pump Catalog or the drawings.
- The setting must not exceed the pump's rated pressure and the motor rating.

●Relief Valve Set Pressure.

- The default setting of relief valve pressure is the cracking pressure.
- The setting must not exceed the pump's rated pressure and the motor rating.
 - Cracking pressure is the pressure at which the relief valve starts to open and allow a certain amount of oil to flow.
- The relief valve can be used as both a safety valve and as an pressure control valve. Two types of relief valves are available (external-return type and internal-return type) depending on the intended purpose.

**Caution:**

When using the internal-return type as the safety valve, do not run the pump continuously more than 30 seconds if running the pump against closed discharge. It could result in pump or motor burnout.

**Caution:**

When using the internal-return type as a pressure control valve, do not make any settings that would allow for the relief amount to exceed 50% of the pump flow rate. This could result in abnormal pump heating or pump damage.

**Caution:**

If an external-return type relief valve is selected, the relief oil must be returned to completely below the tank oil surface.

- Set the relief valve set pressure slightly higher than the pressure actually needed. The necessary discharge amount will not be obtained if oil leaks from the relief valve.

●Applicable Liquids

•Applicable Liquids

Trochoid pumps and Lunary pumps can handle a very wide range of applications, but be aware that these pumps were intended to use with oils.

-2HT and GD series, the trochoid pump for low viscosity, is applicable to fuel oils (except high vapor pressure oils such as gasoline)

-2HW series, the Trochoid pump for coolant, can be used with coolant fluid.

Please consult your coolant water supplier as the pump service life may be significantly shorten or pump may get damaged if operated under a certain oil temperature or environment.

•Trochoid pumps and Lunary pumps adopt a self-lubricating method so that the sliding surfaces and bearings are lubricated by the pumping oil itself.



Caution:

The pump may become damaged if it is used with water, liquids which contain corrosive substances or don't offer lubricity or rust protection.



Caution:

Check with the oil manufacturer (or distributor) for the compatibility of the oil with the Trochoid seal material in advance. Use of incompatible oils may cause leaks.

•It is very rare, though certain operating environment, pumped liquid, swarf or work materials may cause oil leakage and damage the pump. If it is the case, the pump cannot be used.

•Please consult us if using oils with low viscosity as you may need to select a pump specially designed to handle it and maximum permissible operating pressure will also be restricted.



Caution:

The pump may get damaged if using oils with low viscosity.

•Some fuel oils contain properties that will cause the standard oil seals to swell. Be sure to check the compatibility with the oil before use.



Caution:

Do not use gasoline or any other high vapor pressure oils. It could result in explosions or fires.

If you use with fire-resistance fluids, please contact us as there are some seal types which do not have durability against them.

●Ambient Temperature

•Ambient temperature range of Trochoid and Lunary pumps is -20°C ~ 40°C.

•Ambient temperature range of our motor is -10°C ~ 40°C.



Caution:

Operations outside the above temperature ranges could damage the Trochoid pump, Lunary pump or motor, resulting in a serious accident

●Oil Temperature Range.

- The temperature range of the oil is -5 ~ 80°C. (GD-2H is 20 ~ 40°C)
- The models with seal packing code of [VF] can handle the oils within the temperature range of 80 ~ 120°C.
- The models with seal packing code of [VH] can handle the oils within the temperature range of 120 ~ 200°C.
 - The maximum operating pressure is 0.7MPa when the oil temperature is 80°C or higher.
- The temperature gap between the pump and the oil must be within 40°C.
- Normally motor and pump have specified temperature range for the operating environment, so be sure to take measures to keep the oil temperature within that range.



Caution:

Operations outside the above temperature ranges could significantly shorten the Trochoid and Lunary pump's service life, decrease performance and result in leaks. Please consult us if running the pump outside the above temperature ranges, as it may require the pump with special specifications.



Warning:

Pumping a high temperature oil could cause burns from pumps or leaked oil.

●Applicable Viscosity Ranges.

- The permissible viscosity range of oils for Trochoid pump is 10 ~ 500mm²/s.
Refer to "Suction Capacities" on P.14 for your reference.
- The permissible viscosity range of oils for 2HT series (for oils with low viscosity) and 2HW series (for coolant fluids) is 2 ~ 100mm²/s.
- The permissible viscosity range of oils for high-viscosity pumps (3V, Lunary pump) is 46 ~ 2,000mm²/sec.



Caution:

Operations outside of the above viscosity ranges could significantly shorten the service life of the Trochoid and Lunary pumps, decrease performance and result in leaks.

- The volumetric efficiency (discharge amount) drops as the viscosity becomes lower.
- The required power (motor output) increases as the viscosity becomes higher.
 - Low winter temperatures must be taken into account when selecting a motor.
- Please consult us if using oils with low viscosity, as the maximum applicable pressure may be restricted.
- Please consult us for special specifications if running the pump outside the above viscosity ranges.



Caution:

Running the pump in the oil with high viscosity or at high speed may cause pump malfunctions.

●Rotation Direction.

- The rotation, suction and discharge directions of the Trochoid and Lunary pumps are fixed, except for some models that offer forward and reverse rotation. Set the rotation direction of the motor in accordance with the rotation direction displayed on the pump nameplate.
- The Trochoid and Lunary pumps have holes on the pump suction (negative pressure) which are provided to release pressure for protecting the oil seal. If a mistake is made in setting the rotation direction, the suction and discharge positions will be switched. As a result, discharge pressure will flow through the holes which is originally intended to release pressure. This pressure will build up against the oil seal, causing seal break and oil may splash out.

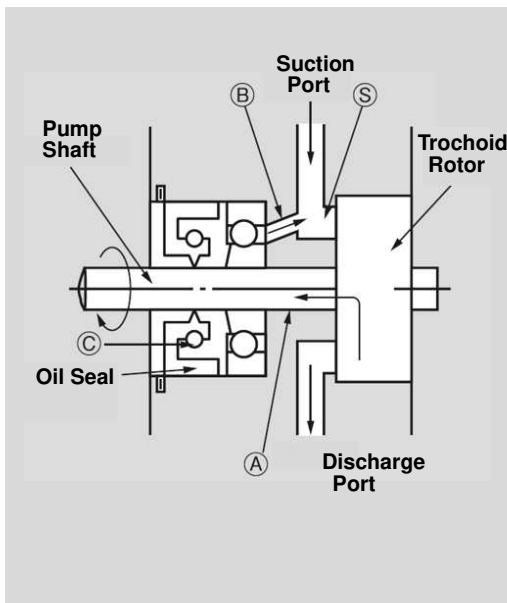

- As shown in the figure on the left, the oil is discharged from the discharge port. When there is a back pressure, the oil passes through the bearing A, lubricates the ball bearing, and stopped by the oil seal. When the pressure exceeds 0.03 MPa (0.3 kgf/cm²), however, the seal may rupture and the oil splashes out.
- A small hole B is provided to return the trapped oil to the suction side. In other words, the oil trapped in space C is always returned to S area. If the pump rotates backwards, the suction port and discharge port will be switched and the oil pressure goes directly to the oil seal through the small hole B. Soon the seal will rupture and end up with oil leakage, as there is no oil passage to release the pressure. Ruptured oil seal must be replaced as the lip is damaged. Please consult us when replacing the oil seal.



Warning:

Be sure to set the pump rotation direction correctly. Mistakes in rotational setting could break the oil seal and the oil may splash out, resulting in unexpected accidents.

Motor Selection

●Required Power for the Pump.

- Select a motor with adequate power margin with reference to the performance curve of the pump on the catalog.
- The power required by the pump will vary depending on pressure, flow rate and viscosity of the oil.
- More power is required as the viscosity of the oil increases.
- Low winter temperatures must be taken into account when selecting a motor.
- The single phase motors do not conform to the motor high-efficiency regulation in USA.

● **Applicable Voltage and Frequency.**

- Make sure that you are applying the correct power voltage and frequency indicated on the motor name plate.

⚠ Caution: Applying an incorrect voltage or frequency could damage the motor or result in abnormal pressure or flow rate.

● **Surroundings of the installation site.**

- Confirm the surroundings of your pump installation site. Select a motor for outdoor use or a explosion-proof motor depending on the surroundings of the installed location.

Pump Drive Method

● **Driving Method.**

- Pump driven by special-purpose motor: Trochoid pump with motor.
- Pump driven by general-purpose motor: Trochoid pump with motor and base coupling or Lunary pump with motor and base coupling.
- Power source other than electric motor: Trochoid pump, Lunary pump.
- Trochoid and Lunary pumps are designed on the premise that the motor and shaft center are arranged in a straight line. Centering of the drive shaft and pump should be within 0.05mm TIR.

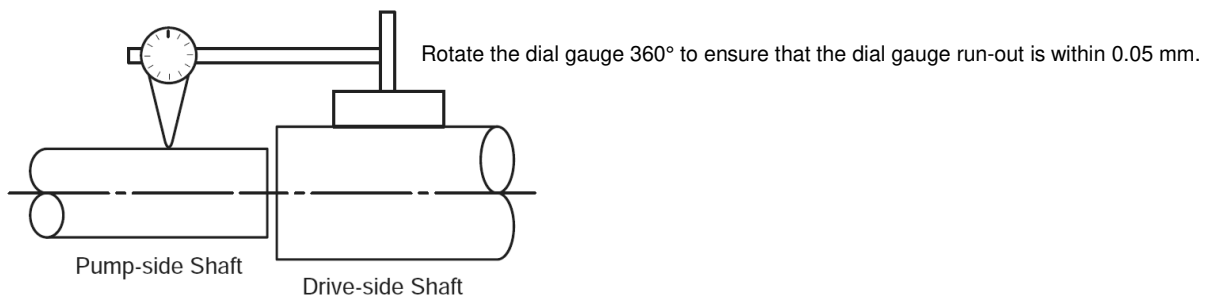

- Please contact us for the drive methods in which the load is placed on pump shaft along radial or thrust direction.

⚠ Caution: Poor alignment between the motor and the Trochoid or Lunary pump may result in vibrations, loud noises and damage to the pump.

⚠ Caution: When attaching the coupling to the pump shaft, do not forcibly hammer the coupling into place. It could result in pump malfunctions.

⚠ Caution: Placing thrust load or radial load on the pump shaft may cause pump malfunctions.

Suction Capacities

- Set the suction head for the Trochoid and Lunary pumps within 1 m when running the motor at a speed of $1,000 \sim 2,500\text{min}^{-1}$ or keep the suction pressure at the suction port within $-0.03 \sim 0\text{MPa}$ when the port is fully filled with oil.
- Pressure on the suction side lower than -0.03MPa could result in cavitation, abnormal noise, heating, poor discharge and damage to the pump.
- Please consult us if the pump should be operated outside the specification range as stated above.



Caution:

Suction capabilities will drop when there is large resistance in the discharge line.



Caution:

Suction capabilities will drop significantly when air enters from the suction line.

- The pump must be mounted at a position below the oil surface level if running the pump at slow speed.

Troubleshooting Chart

• If you experience no oil discharge, a high pitched sound, or such other abnormal phenomena soon after the installation, check the troubleshooting chart in the table that follows. If you cannot find out the cause of trouble, consult us or your dealer.

Pump Troubleshooting Chart

Symptom	Possible causes	Check methods	Possible remedies
Insufficient flow or pressure. Pump doesn't draw oil.	Discharge amount is insufficient or no oil discharge.	• Measure the suction pressure with vacuum gauge, the suction pressure lower than -0.03MPa may cause cavitation.	• Replace the oil with lower viscosity.
		• Check for suction pipe clogging. Check out the suction filter if it's clean.	• Clean out the suction filter.
		• Not enough oil in the tank. • Check the oil level with level gauge or make a visual check.	• Fill the tank with oil up to the specified level. Guide line: The amount of oil which is 3-4 times larger than the pump flow rate.
		• Is the pump drawing air from the pipe joints?	• Retighten the pipe joints.
		• Viscosity of oil is too low for the intended pressure.	• Change the viscosity of oil to the suitable level for your pump.
		• Tighten up the relief valve pressure control screw while referring to the pressure gauge. Result : Pressure won't build up.	• Clean out the relief valve or remove foreign object as something might get stuck in the relief valve.
		• Tighten up the relief valve pressure control screw while referring to the pressure gauge. Result : Pressure builds up.	• Set pressure is too low. Raise the set pressure as oil is leaking through the relief valve.
		• The pump is rotating backward. • Visual check of rotation direction.	• Change the direction of rotation as indicated on the pump.
Oil leaks.	Oil leaks from oil seal.	• Is the pump rotating in correct direction?	• Repair or replace pump.
		• Is suction pipe pressurized?	• The pump should be mounted at a position higher than oil surface level. • Pressure resistance of oil seal must be within the range of 0 ~ 0.03MPa. • If check valve (NRV) is installed in the suction line, pressure may be trapped inside the discharge line and as it has nowhere to go, the whole pressure will be applied on oil seal area.
		• Oil temperature exceeds maximum resistance temperature of oil seal.	• Oil seals for special materials also can be supplied if requested.
		• Oil is incompatible with oil seal materials.	• Replace seal or pump.

Symptom	Possible causes	Check methods	Possible remedies			
No oil discharge. Breaker trips.	Motor doesn't rotate.	• Blackout or voltage drop.	• Check the power supply equipment.			
		• Solenoid valve or breaker trips.	• Reset the Solenoid valve, breaker.			
		• Power supply is disconnected or has a poor connection.	• Replace or reconnect the cable.			
	Overloading.	• Is power rating adequate for the operation.	• Use motor with higher output rating. • Use pump with lower capacity. • If you find it difficult to choose the right motor or pump, please consult us after checking oil viscosity, required pressure and pipe layout.			
Pump won't rotate or rotate unsmoothly by hand.	• Are viscosity and lubricity of the oil adequate?	• Rotor galling or foreign object stuck inside the pump.				
	• Is the oil fairly clean?	• Repair or replace pump.				
Loud noise. Abnormal noise.	<ul style="list-style-type: none"> • Suction resistance is too high (cavitation). • Suction pipe is too narrow. • Suction pipe too long. • Motor speed is too fast. • Suction filter has a large resistance. • Oil viscosity is too high. • Suction lift is too high. 	<ul style="list-style-type: none"> • Measure the suction pressure with vacuum gauge. • Cavitation must be occurring if suction pressure is lower than -0.03MPa. 	<ul style="list-style-type: none"> • Make sure that suction pressure is within -0.03 ~ 0MPa (Close to atmospheric pressure). • Replace with larger pipes. • Make the pipe length shorter • Replace with filters in which the resistance is smaller. • Replace with oil with lower viscosity. • Lower the suction lift. 			
				• The pump is drawing air (Airation).	• Is there foam inside the tank? • Is there loose pipe connections?	• Make sure that air doesn't enter the tank, pipes and inside the pump.
					• Check if returned pipe is under the oil surface or not.	• Make sure that the returned pipe is always under the oil.
	• Misaligned coupling.	• Check the concentricity of couplings and shaft alignment.	• Make sure that the coupling's concentricity is within the specified level.			

NOP® Nippon Oil Pump Co., Ltd.

Revision number : T201806EN

For further information :

HP : <http://www.nopgroup.com>

Tel : +81-3-6402-4041

Fax : +81-3-3436-1777

Sumitomo Fudosan Higashi Shimbashi
Building-6 3F, 1-2-4 Hamamatsucho,
Minato-ku, Tokyo, Japan, 105-0013

Your dealer :